

Optical Character Recognition with Neural Network

Sarita

M. Tech DCRUST (Sonipat)

ABSTRACT: A neural network is defined a computing architecture that consist of massively parallel interconnection of simple neural process. Because of its parallel nature it can perform computation at a higher rate compared to the classical techniques. A neural network contains many nodes. OCR is the acronym for Optical Character Recognition. This technology allows a machine to automatically recognize characters through as optical mechanism. Character reorganization device is one of such smart devices that acquire partial human intelligence with the ability to capture and recognize various characters and digits. Character recognition techniques help in recognizing the characters written on paper documents and converting it in digital form. So Character recognition is gaining interest and importance in the modern world. While the area of character recognition is vast we focus on the fundamentals of character recognition, available techniques and emphasis on more recently used technique, neural networks. Recognizing characters, letters or digits for human beings is not a big task. It can even be done by small child, but doing the same with machine is a difficult task. Machine simulation of human functions has been a very challenging research area since the advent of digital computers. Character recognition techniques help in recognizing the characters written on paper documents and converting it in digital form. So Character recognition is gaining interest and importance in the modern world. The paper throws light on, one of the application of Neural Network (NN) i.e. Character Recognition.

Keywords: OCR, NN, CRS, Knowledge-base

I. INTRODUCTION

Recognizing characters, letters or digits for human beings is not a big task. It can even be done by small child, but doing the same with machine is a difficult task. Machine simulation of human functions has been a very challenging research area since the advent of digital computers. The ultimate goal of designing a character recognition system with an accuracy rate of 100 % is quite illusionary because even human beings are not able to recognize every hand written text without any doubt. For example, many people can not even read their own note. Alphabet recognition is one of the most successful applications of neural network technology. In alphabet recognition, printed documents are transformed into ASCII files for the purpose of editing, compact storage, fast retrieval through the use of computer. The recognition of alphabet in a document becomes difficult due to noise, distortion, various alphabet fonts and size. Many type of techniques for alphabet recognition of several languages such as English, Hindi, Arabic, Chinese have been published but still recognition of alphabets using neural network is an open problem in terms of high recognition accuracy and minimum time of alphabets. Neural network has a wide application in

the field of pattern recognition. The network can be used to learn the alphabet in the format of patterns and then generalizing from the trained network and recognize the alphabet that is presented in the form of image.

II. CATEGORIZATION OF CRS

Character recognition system can be classified based upon two major criteria.

Classification According To Data Acquiring Process

Online CRS

Recognizing handwriting recorded with a digitizer as a time sequence of pen co ordinates is known as online character reorganization. It captures the temporal or dynamic information of writing. This information consist of pen strokes (i.e. the writing from pen down to pen up), the order of pen strokes the direction of writing and the speed of writing within each stroke.

Offline CRS

It is also known as “optical character recognition” because the image of writing is converted into a bit pattern by an optically digitized device such as optical scanner or camera. The bit pattern data is shown by matrix of pixels. These matrixes can be very large so in order to reach the complexity and to insert much data in

recognition most scanners are designed to have x-y optical scanning devices or the writing instruments resolution of typically 100 – 1600 dots per inch.

Categorization According To Text Type

Printed CRS

Printed text includes all the printed materials such as book, newspaper, magazine and documents which are the output of typewriters, printers or plotters. The recognition rate is very much dependent on the age of the documents, quality of the paper and ink which may result in significant data acquisition noise [1].

Hand written CRS

Hand written character recognition, based on the form of written communication can be divided into two categories: Cursive script and Hand printed characters. It is the most difficult part of character recognition area because depending on the style of the writer and the speed of the writing some character may vary in size and shape [2].

III. MODEL FOR CHARACTER RECOGNITION

For any character recognition system there are four major stages, as shown in the figure below:

- Pre-processing
- Segmentation
- Feature extraction
- Training and recognition / classification [2].

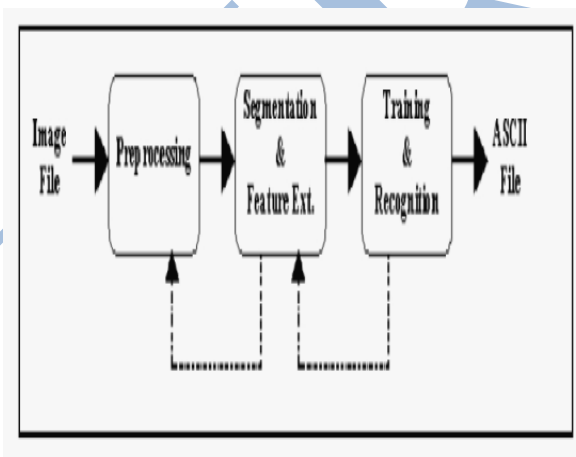

Figure:1 Procedure of character recognition

Pre-Processing

Pre-processing is done prior to the application of segmentation and feature extraction algorithms. It aims to produce clean document images that are easy for the character recognition system to operate accurately. The major objective of pre-processing are as listed below:

Noise reduction: The noise which is introduced by the

optical scanning devices or the writing instruments causes disconnected line segments, bumps and gap in lines, filled loop etc. There are many techniques to reduce noise like filtering and morphological operations. Normalization: Normalization methods aim to remove all type of variations during the writing and obtain standardized data. The basis methods for normalization are skew normalization, slant normalization and size normalization.

Compression: In addition to classical loss less image compression techniques the character can be further compressed by thresh holding and thinning algorithms.

Segmentation

The pre-processing stage yields a clean document in the sense that maximum shape information with minimal noise on normalize image is obtained. The next stage is segmenting the document into its sub components and extracting the relevant features to feed the training and recognition stages. There are two types of segmentations as listed below.

External segmentation:It is isolation of various writing units such as paragraph, sentences or word prior to recognition. It decomposed the page layout into its logical parts. This is done in two ways i.e. Structural analysis and Functional analysis.

Internal segmentation:It is an operation that seeks to decompose an image of sequence of characters into sub images of individual symbols. Character Segmentation strategies are divided into following categories.

Segmentation by dissection method:It identifies the segments based on character like properties. This process of cutting of image into meaning full components is given a special name, dissection. Dissection is an intelligent process that analyses an image without using any specific class of shape information. Available method based on dissection of an image is connected component analysis.

Recognition based segmentation:It searches the image for components that match pre defined classed. Segmentation is performed by use of recognition confidence including syntactic or semantic correctness of the overall result.

Feature Extraction

A good feature set plays one of the most important roles in a recognition system. A good feature set should represent characteristic of a class that help distinguish it from other classes. The features can be classified as below:

Global transformation and series expansion features: These features are invariant to global deformation and rotations. One way to represent a signal is by linear combination of a series of simpler well defined functions.

Statistical features: These features are derived from the statistical distribution of points. They provide high speed and low complexity and may also be used for reducing the dimension of feature set.

Geometrical and topological features: These features may represent global and local properties of character and have high tolerance to distortion [4].

Training And Recognition Techniques

As in many areas of image analysis, character recognition systems extensively use the methodologies of pattern recognition which assigns unknown samples into pre defined classes. Character recognition finds its roots from pattern recognition. Pattern recognition is a study of how machines can observe the environment, learn to distinguish patterns of interest from their backgrounds and make sound and reasonable decisions. Pattern recognition is a study of how machines can observe the environment, learn to distinguish patterns of interest from their backgrounds and make sound and reasonable decisions.

Pattern Matching

Here the memory representation is a holistic unanalyzed entity (a template). An input pattern is compared to the stored representation. The identity is determined by the selection of template with the greatest amount of overlap. The stored representation is the description of past inputs in terms of list of attributes or features. Inputs are broken down into a small list of constituent features. Identity is determined by selecting the feature list most similar to the input, but this technique faces some severe problems. This technique is intolerant to deviations. Large number of template is required and can not support similarity-difference judgments [5].

Statistical Approach

Here each pattern is represented in terms of d - features or measurements and is viewed as point in a d -dimensional space. The goal is to choose those features that allow pattern vectors belonging to different categories to occupy compact and disjoint regions in d -dimensional features. Given a set of training patterns from each class the objective is to establish decision boundaries in the feature space with separate patterns belonging to different classes. One way to do this is by clustering analysis. Clustering can be performed either

by an agglomerative or a divisive algorithm. The agglomerative algorithm operates step by step merging small clusters into large ones by a distance criterion. The divisive method splits the characters under the certain rules for identifying the underlying characters.

Artificial Neural Networks

Artificial Neural Network (ANN) is information processing paradigm that is inspired by the way biological nervous systems, such as the brain, process information. The key element of this paradigm is the novel structure of the information processing system. It is composed of a large number of highly interconnected processing elements (neurons) working in unison to solve specific problems. ANNs, like people, learn by example. An ANN is configured for a specific application, such as pattern recognition or data classification, through a learning process. Artificial Neural Network (ANN) is a collection of very simple and massively interconnected cells. The cells are arranged in a way that each cell derives its input from one or more other cells. It is linked through weighted connections to one or more other cells.

Applications of ANN:

- Speech Recognition
- Classification of radar signals
- Remote Sensing and image classification
- Handwritten character/digits Recognition
- ECG/EEG/EMG Filtering/Classification
- Credit card application screening
- Data mining, Information retrieval of Artificial neural network
- Machine Control/Robot manipulation
- Financial/Scientific/Engineering Time series forecasting.
- Inverse modeling of vocal tract

IV. NEURAL NETWORKS

Classical methods of pattern recognition are not considered to be so successful for recognition of characters due to following reasons:

- The same character differs in size, shape and style from person to person and from time to time with the same person.
- Like an image visual characters are subject to spoilage due to noise.
- There is no specific rule that defines the appearance of visual character.

Image digitization: The process of digitization is important for neural networks. In this process the input

image is sampled into binary window which forms the input to the recognition system. The sample of this process is shown in the figure below:

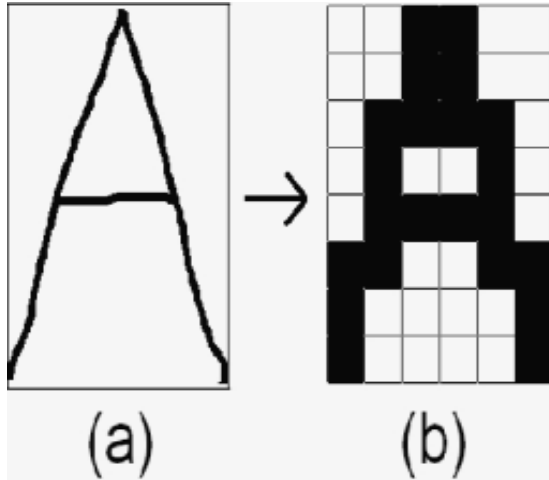

0 0 1 1 0 0
 0 0 1 1 0 0
 0 1 1 1 1 0
 0 1 0 0 1 0
 0 1 1 1 1 0
 1 1 0 0 1 1
 1 0 0 0 0 1
 1 0 0 0 0 1

In the figure the alphabet A is digitized into 6X8=48 cells, each having a single color black or white. This is done in order to make the computer understand the form. And in the process of digitization cell with color black is further assigned value +1 and the cell with color white is assigned a value 0, to give it binary structure. And this creates a binary image matrix I [3]. This makes input image invariant of actual dimensions architecture of Neural Network studied:

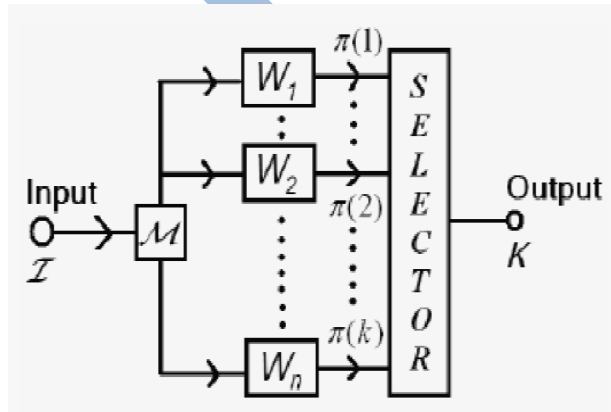

The architecture of the neural network which formed the basis for this study is as shown in the figure above. Here the input to network is pattern I . The block M provides the input matrix M to the weighted blocks W_k for each K . There are total of n weighted blocks for n characters to be learned [4].

Learning Process: In this process a character is assigned to the network and is given a label. Several other patterns of the same character are taught under the same label, due to which system learns several variations of a single pattern and gets adaptive to it. During this training process the input assigned is matrix M defined as below:

$$\begin{aligned} & \text{If } I(i, j) = 1 \text{ Then } M(i, j) = 1 \\ & \text{Else:} \\ & \text{If } I(i, j) = 0 \text{ Then } M(i, j) = -1 \end{aligned}$$

In this method of learning, each character to be taught; processes corresponding weight matrix. For the K th character to be taught its weight matrix is denoted by W_k . As the learning of the character progresses it is the weight of the character to be updated. At the commencement of teaching (supervised training), this matrix is initialized to zero. The network is then instructed to identify this pattern as, say, the k th character in a *knowledge base* of characters. That means that the pattern is assigned a label k . In accordance with this, the weight matrix W_k is updated in the following manner:

$$\begin{aligned} & \text{For all } i = 1 \text{ to } x \\ & \{ \\ & \text{For all } j = 1 \text{ to } y \\ & \{ \\ & W_k(i, j) = W_k(i, j) + M(i, j) \\ & \} \\ & \} \end{aligned}$$

Here x and y are the dimensions of the matrix W_k (and M).

The figure below shows the digitization of three input patterns representing S that were presented to the system for it to learn.

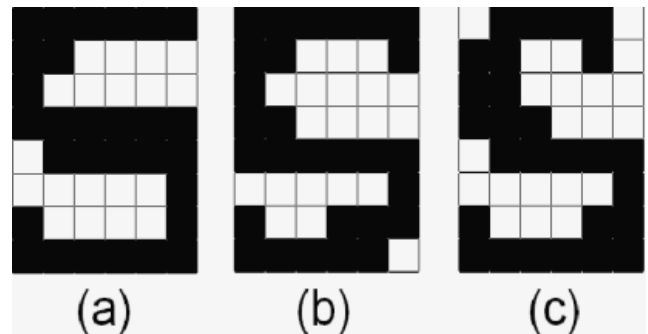

We can see that the patterns slightly differ from each other, just as handwriting differs from person to person (or time to time) and like printed characters differ from machine to machine [6].

The figure below gives the weight matrix, say, WS corresponding to the alphabet S . The matrix is has been updated thrice to learn the alphabet S . This matrix is specific to the alphabet S alone. Other characters shall each have a corresponding weight matrix.

V. APPLICATIONS OF CHARACTER RECOGNITION

- 1 Personal organizer, Personal communicator, Notebook.
- 2 Data acquisition devices for order entries, inspection, inventories, survey etc.
- 3 Large scale data processing such as postal address reading, cheque sorting.
- 4 Shorthand transcription.
- 5 Reading aids for visually handicapped.

VI. CONCLUSION

The basic idea of using extracted features to train a Neural Network seems to work, although the success rate is not impressive, it could have been worse. There are several possible changes that could improve the performance. In this paper the neural network approach explained here shows the learning ability and adaptability of neural networks. Despite the computational complexity involved, artificial neural networks offer several advantages in pattern recognition and classification in the sense of emulating adaptive human intelligence to a small extent.

VII. REFERENCE

- [1]. S.C Tripathi, Vijay Kumar, "Character Recognition a Neural Network Approach", National Conference on Advancement of Technologies – Information Systems & Computer Networks (ISCON – 2012) Proceedings published in International Journal of Computer Applications (IJCA).
- [2]. K.Venkata Reddy, D.Rajeswara Rao, U.Ankaiah, K.Rajesh, "Hand Written Character And digit Recognition Using Artificial Neural Networks", International Journal of Advanced Research in Computer Science And Software Engineering, Volume 3, Issue 4, April 2013.
- [3]. Hussain, B and Kabuka, M. R., "A novel feature recognition neural network and its application to character recognition", IEEE Transactions of Pattern Recognition and Machine Intelligence, Vol.16, No.1,1994,pp.98-106.
- [4]. Statistical Pattern Recognition: A Review By Anil K Jain, Robert P.W. Duin and Jainchang Mao, IEEE transaction on Pattern Analysis and Machine Intelligence, VOL.22, No.1, January 2000.
- [5]. An offline character recognition system for free style handwriting: A thesis submitted to the Graduate School of Natural and Applied Sciences of Middle East Technical University, By Nafiz Arica
- [6]. G. G. Rajput, Rajeswari Horakeri, Sidramappa Chandrakant, "Printed and Handwritten Kannada Numeral Recognition Using Crack Codes and Fourier Descriptors Plate", International Journal of Computer Application (IJCA) on Recent Trends in Image Processing and Pattern Recognition (RTIPPR), pp 53-58, 2010.
- [7]. Demuth H., Beale M. and Hagan M. (2006). Neural network toolbox for use with MATLAB. Neural Network Toolbox, IEE Savoy Place, London.
- [8]. Cognimem, CogniMem_1K: Neural network chip for high performance pattern recognition, datasheet, Version 1.2.1, www.recognetics.com, 2008.
- [9]. Xilinx, Inc. Xilinx Synthesis Technology (XST) User Guide. UG627 (v 11.1.0) www.xilinx.com, 2009.
- [10]. L. Leiva, M. Vázquez, N. Acosta, G. Sutter, "Herramienta de Generación de Arquitecturas Hardware para Reconocimiento de Patrones en Imágenes", JCRA 2007: Jornadas de Computación Reconfigurable y Aplicaciones.