

Design and Implementation of Microcontroller Based Automated Dust Cleaning System to Improve Efficiency of Photovoltaic Cells

G.Mohana¹, B.Naveenkumar², P.Srikanth³, B.Asfiya⁴

^{1,2,3,4} UG Scholar, ⁵ Assistant Prof/EEE

Department of EEE, Sengunthar College of Engineering

Abstract- The solar cell modules are generally employed in dusty environments which is the case in tropical countries like India. The dust and particulate matter gets accumulated on the reflecting surface of the module and blocks the incident light from the sun. It reduces the power generation capacity of the module. The power output will be decreased as much as up to 50% if the module is not cleaned for a long time. In order to regularly clean the dust, an automatic cleaning system has been designed, which senses the dust on the solar panel and also cleans the module automatically. This automated system is implemented using ARDUINO microcontroller which controls the DC geared motor. This mechanism consists of a two sensors (LDR and PPM). For cleaning the PV module, a mechanism consists of sliding brushes has been developed. In terms of daily energy generation, the presented automatic-cleaning scheme provides about 30% more energy output when compared to the dust accumulated PV module.

Keywords: Solar Cell, Cleaning, ARDUINO, DC Geared Motor, PV Module

I. INTRODUCTION

Solar cell efficiency refers to the portion of energy in the form of sunlight that can be converted via photo voltaic into electricity. The efficiency of the solar cells used in a photovoltaic system, in combination with latitude and climate, determines the annual energy output of the system. Most of the applications nowadays like heating water, agriculture and industrial applications use the solar panels as an electrical power source instead of relying on the generators or the ordinary sources for electricity. The most important part of these systems is the solar panel where the solar energy is converted to heat for water heating or converted to electricity for the others. There are many types of the solar panels. In the countries those have dusty environment accumulation of dust on the solar panels leads to reduction of the transmittance of the panel. Solar desalination plants in some of the middle-east countries like the solar desalination plant of Abu Dhabi suffers from the deposition of dust on its solar plates. The effect of the accumulated dust can be evaluated and implied to use that data to reduce with the increasing of tilt angle, since the tilt angle will affect the exposure time to the sunlight also. But the best way to eliminate the effect of the accumulated dust on the solar panels is to clean the panels. So in this paper we are proposing an automatic

DESIGN CONCEPT

In this paper the effects of accumulated dust on the performance of the solar panels are investigated by referring the results obtained by experimentation in dusty

atmosphere of different levels. Also, an auto cleaning system to work as the auto cleaner which is equipped on the flat solar panel is proposed. The design of the auto cleaning system will be flexible in order to fix on different sizes of solar panels. In accordance with the dimensions of the flat plate panel, the robot consists of brushes driven by DC geared motors through conveyer belt system. The movement of the brushes is controlled by signal generated through a microcontroller in accordance with the high sensitivity dust sensor. The motor will now generate a rotational motion which in turn gives a linear motion for the brushes and the system now starts to clean the panel. Firstly choosing the right kind of sensors which can actually give proper responses.

- a) Now a prototype of the whole system is to be developed.
- b) Designing of the prototype which can work in the real time environment of the project.
- c) Choosing a basic and right kind of microcontroller which can control the whole system in right direction.

HARDWARE DESIGN

The proposed model is based on the working of overhead crane system to clean the surface of solar panel. A two strip track is made for movement of crane system for brushes. The tracks are provided with two dc geared motor which does the forward and backward movement of the brush. These motors are controlled by the motor driver IC L293D. The whole system is controlled by the IC of AtMega 8 based arduino

system. It consists of 5 LDR sensors with different sensitivity. Two of the sensors for providing obstruction to the wheels. And one for the dawn and dust condition of the sun knows as differential measurement unit (DMU). One LDR with higher sensitivity to acknowledge dust on the solar plate. The basic working of the system is like that if dust acquires the panel then sensor gives response to the processor then system is activated and a water sprinkler gets on which is controlled by the MOSFET IC providing power. Firstly the water is spread on the panel and simultaneously the cleaning system gets on with forward and backward motion. Then cleaning system again gets on to totally clean the panel. In this way the lost efficiency is recovered by this module.

The major advantage of the whole system is that it operates on a dc supply with heavy duty rechargeable batteries. And the power which is generated by the solar module can be reused to charge the battery. So, this system provides recycling of power without utilizing any external power source.

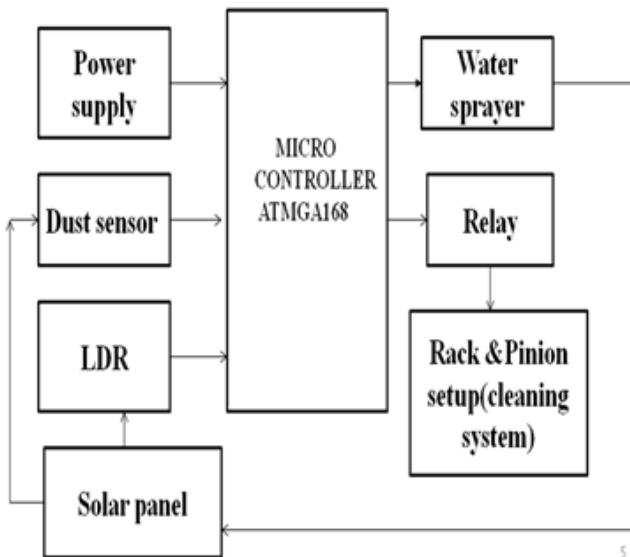

CLEANING MECHANISM

Wiper -Using a battery, we applied 12V at the motor connected to the panel to verify the wiper movement across the panel.

Sprayer-We could not test the valve with water in the lab. However, after the demo, we went outside and connected a water supply to the panel using a garden hose. Then, using a battery, we applied 12V at the solenoid valve. This allowed water to be sprayed onto the panel.

The fully assembled system was able to detect a shaded cell from debris. Furthermore, it initiated the wiper motion down and up the panel to clear the debris. Also, the system maintained the battery charged when there was no cleaning and sufficient power was available. More importantly, the project decreased the daily energy lost compared to the case where the PV panel was left shaded for an entire day. In order to determine energy savings, the PV Panel was placed under

a solar test bed under identical conditions to test the energy loss from one

half shaded cell. The losses due to shading alone was determined by taking the difference between the maximum power of the unshaded PV Panel and the maximum power of with one PV cell half shaded. The power losses of the entire Automated Self-Cleaning Solar Panel was also measured. Energy loss was normalized for one day of operation with one cleaning cycle. The resulting percent energy savings is shown in Equation

$$\% \text{Energy Saved} = \frac{\text{Total Energy Saved}}{\text{Total Shading Energy Loss}} = \boxed{39.9\%}$$

Table 1:

	Electronic Load Power (W)	Electronic Load Current (A)	Time (sec)	Energy (Ws)
Unshaded Panel	4.8	0.13	86400	414720
One Cell Half Shaded	2.7	0.074	86400	233280
ENERGY LOSS DUE TO SHADING				181440

CIRCUIT DIAGRAM:

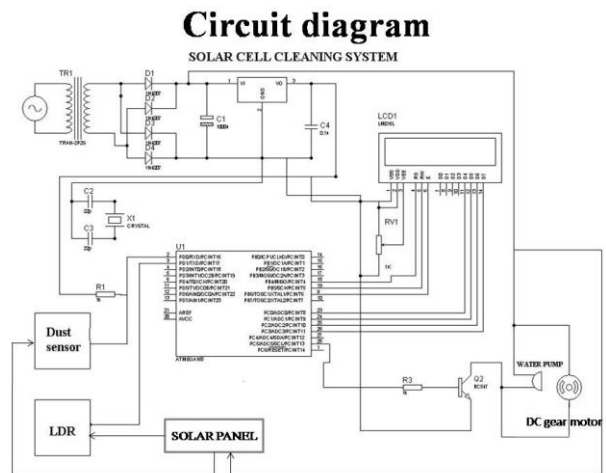

2.Circuit diagram

UNCERTAINETIES

Although our project worked almost exactly as we had planned, and each group member was satisfied with our final product, there were still some uncertainties that we could not address during the duration of this course.

One uncertainty was whether we could make a significant long-term profit. We were able to perform preliminary tests and calculations to determine our daily, or even weekly, profit from the design. But we could not extrapolate that data to estimate our profit on a monthly or yearly basis because of the possibility of fluctuations in weather and long-term maintenance costs.

Another concern we had was marketability. What areas would our project be beneficial for? Would it be more beneficial on a residential scale, or an industrial scale? All these questions

need to be addressed before our product can be produced on a large scale

FUTURE WORK

Even though our project worked perfectly and was functioning as initially planned, there are still a lot of improvements that can be made to make it more marketable and efficient.

First of all, we would like to deal with reducing the friction losses in our project. It is something we did not account for since our panel was prepared by the ECE Machine Shop. We could use a better, and more lubricated ball-screw which would significantly reduce our friction losses. We would also work on making our project more marketable by designing and ordering a PCB. This would make our circuit look neat, and would also reduce its size considerably.

We would like to make our DMU more universal. We could make our DMU wireless, which would allow us to relay data back to a central monitoring system.

Research public opinion and determine whether people would be willing to pay for the long-term savings that our project promises

REFERENCES

G. Masters, Renewable and Efficient Electric Power Systems, Hoboken, NJ: John Wiley & Sons Inc., 2013.

A. S. Sedra and K. C. Smith, Microelectronic Circuits, 6th ed., New York, New York: Oxford University Press, 2010.

"IEEE Code of Ethics," [Online]. Available: <http://www.ieee.org/about/corporate/governance/p7-8.html>. [Accessed 18 March 2014]. Industries, Semiconductor Components, datasheet, MC34072, 21st ed., 2013.

P. T. Krein, Elements of Power Electronics, 1st ed., New York: Oxford University Press, 1998.

Sealed Lead Acid Battery, datasheet, UPG. Available at: <http://powerupco.com/site/wp-content/files/Batteries/UPG/UB1270.pdf>.

Texas Instruments Incorporated, datasheet, LM78LXX Series 3-Terminal Positive Regulators, 2013.

Texas Instruments Incorporated, datasheet, LP2950 Series of Adjustable Micropower Voltage Regulators, 2013.

Texas Instruments Incorporated, datasheet, LM2678

SIMPLE SWITCHER High Efficiency 5A

Step-Down Voltage Regulator, 2013.

L298 Dual Full-Bridge Driver, datasheet, STMicroelectronics, 2000. Available at: https://www.sparkfun.com/datasheets/Robotics/L298_H_Bridge.pdf.

Understanding a Microswitch. Youtube. [Online]. Available: <https://www.youtube.com/watch?v=q6nP1FjxAMU>.

Controlling motors with an MSP430 (or Arduino). Maker Dreams. [Online]. Available: <http://lars.roland>

[.bz/controlling-motors-with-an-msp430/](http://lars.roland.bz/controlling-motors-with-an-msp430/).

Plastic Water Solenoid Valve. Adafruit. [Online]. Available: <http://www.adafruit.com/products/997#Description>.

Microcontroller Interfacing Circuits, 2000. [Online]. Available: http://faculty.unlv.edu/pushkin/microcontroller_interfacing_reolution.pdf.

Qin, Shubin; Kim, K.A.; Pilawa-Podgurski, R.C.N., "Laboratory emulation of a photovoltaic module for controllable insolation and realistic dynamic performance," Power and Energy Conference at Illinois (PECI), 2013 IEEE, vol., no., pp.23,29, 22-23 Feb. 20.